

Model No.	SCL3000A
Capacity	3000Kgs
Vertical Travel	1800mm
Operation	Push Button(24V)
Power	3PH 220/380/400/415V 50/60HZ
Drive System	Electro Hydraulic
Motor	1.5KW 4P·10minutes Rating
Lifting Speed (when 3,000kgs. Loaded)	Approx. 58sec (50HZ) Approx. 48sec (60HZ)
Lowering Speed (when 3,000kgs. Loaded)	Approx. 28sec
Distance between Lift Center	1400mm
Applicable Vehicles	Passengers vehicle
Machine Weight	Lift unit-850Kgs., Hyd. Unit-190Kgs.
Oil	ISO VG32
Oil Volume	15L
Air Pressure	0.5MPa~1.0MPa
Noise Level	70dB (A)

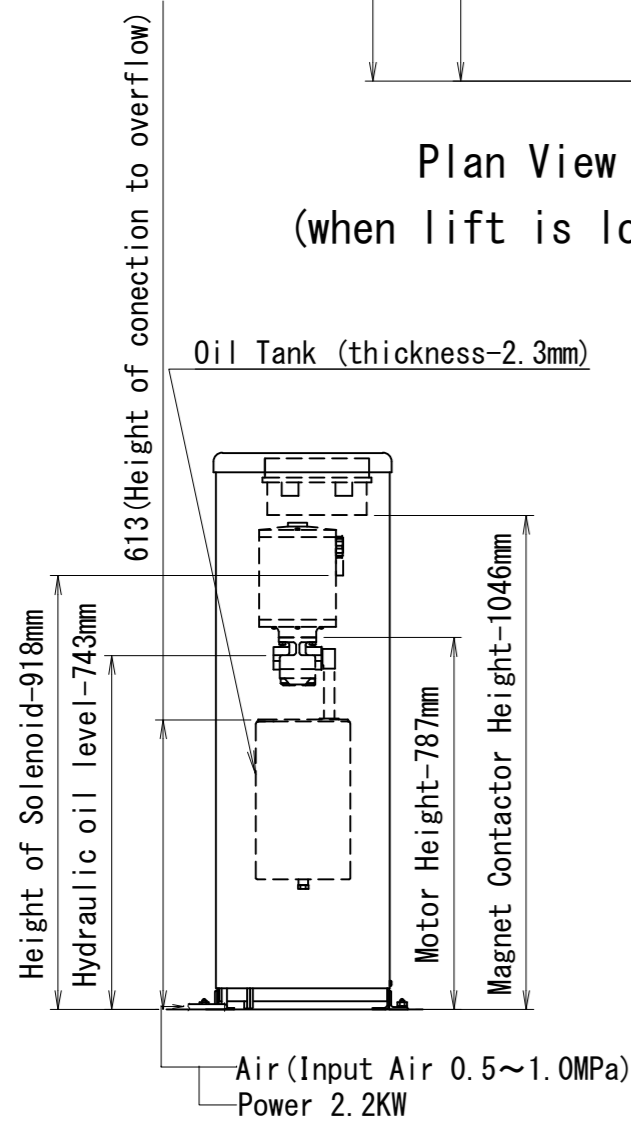

Hydraulic Unit

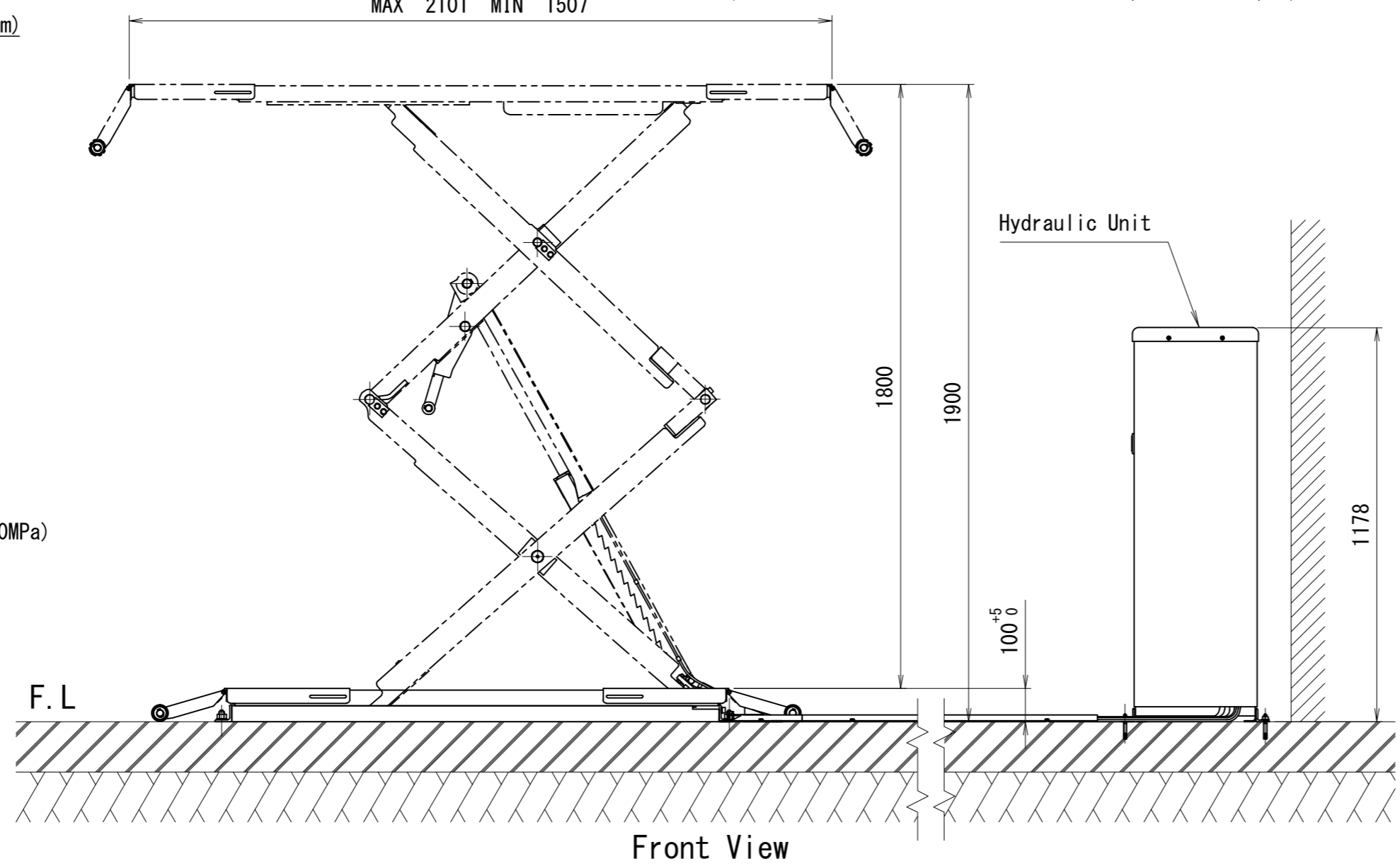

Front View

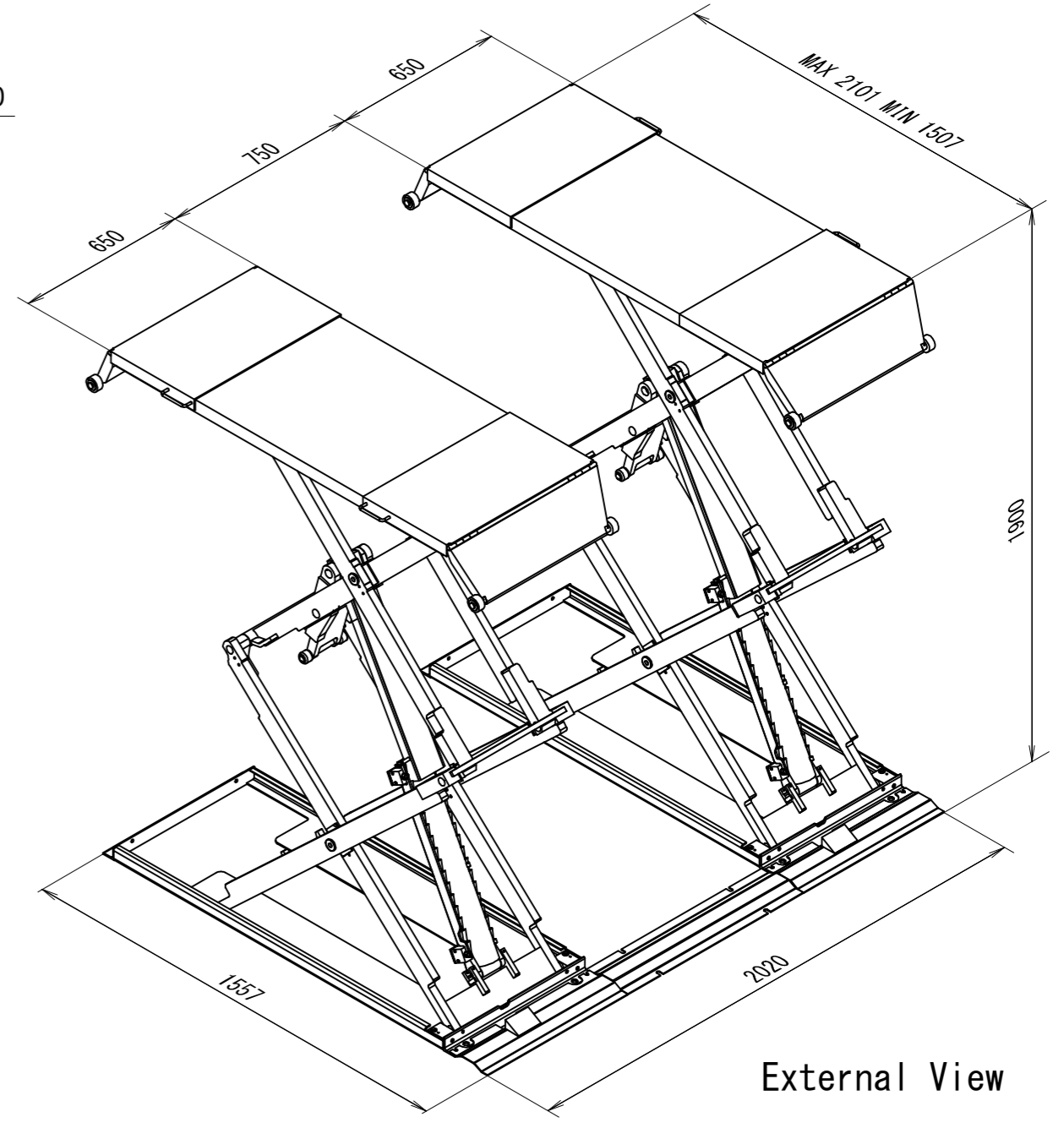

External View

- Note 1 : Lift need to be installed on flat floor horizontally. In case there is gap of concrete under the Base Rollers, fill the mortar etc. to make flat
- Note 2 : Concrete floor must be strong enough to bear 4 ton weight under the lift
- Note 3 : Connect the lift and hydraulic unit with supplied hydraulic hose
- Note 4 : Air (Input Air 0.5~1.0MPa)
- Note 5 : Cut the Piping Cover L according to the piping between lift and Hydr. Unit

株式会社スギヤス									
品名 SCL3000A Installation Drawing									
検図番号 SCL3000A -022000-07									
1 2 3 4 5 6 7 8 9									日付
									2018/08/02
製 石									尺 度
									1:16

訂正	年月日	記	事	担当承認
----	-----	---	---	------