

COMPACT SCISSOR LIFT

ELECTRO

[TORTOISE III]

CAPACITY 3,200kg

Pit Model

Key Features

FULL FLAT at BOTTOM

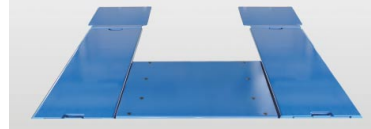

Drive-on plates become fully flat same as floor level at the bottom for easy drive in.

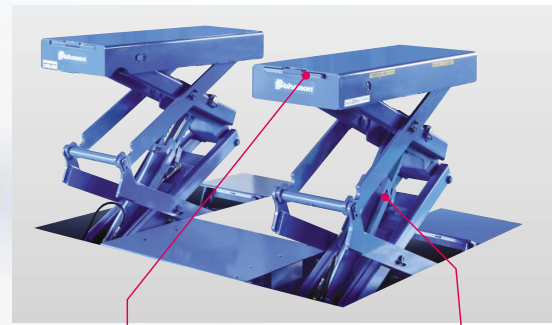

SLIDING SUPPORTER
Easy sliding of Supporter
Range - Min 1,320mm~
Max 2,180mm



SUPER STURDY SCISSORS DESIGN
Inner Scissors use Square tube for sturdy structure against bending and swing

MECHANICAL SYNCHRONIZING SYSTEM

Mechanical Synchronizing System provides reliable synchronizing between both sides of Drive-on Plate when lifting unbalanced.



Specifications

BSC3200KU

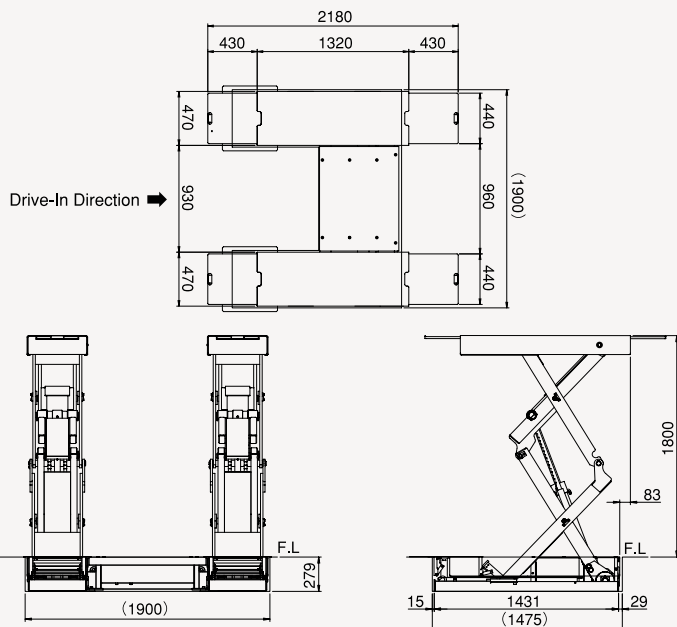

Model No.	BSC3200KU	
Installation	Pit installation	
Hyd. Unit	Built-in	
Capacity	3,200kg	
Vertical Travel	1,800mm	
Control	Cable remote control switch	
Power	3 phase	
Lifting Time (Approx)	60Hz	43 sec.
	50Hz	52 sec.
Lowering Time (Approx)	40 sec.	
Motor	2.2kW 4P 5 min. rating	
Oil Volume	18L (ISO VG32)	
Air Pressure	0.7MPa	

※ () shows the pit spec.